

REPLICATION OF A STATE FEEDBACK CONTROLLER WITH STATE OBSERVER BY A RECURRENT NEURAL NETWORK FOR APPLICATION IN THE ACTIVE CONTROL OF VIBRATIONS

FÁBIO M. U. ARAÚJO E TAKASHI YONEYAMA

*Departamento de Sistemas e Controle, Instituto Tecnológico de Aeronáutica
CEP 12228-901 – São José dos Campos, SP, BRAZIL
meneghet@ele.ita.br, takashi@ele.ita.br*

Abstract— This paper tackles the problem of replicating a dynamical controller by a recurrent neural network applied to the active control of vibrations. The objective is to reduce vibrations in an electromechanical system consisting of a lever supported in two points. The main support has a DC servo-actuator to provide vertical displacements, in the center of the lever, which is used for disturbance suppression. The other support is passive, consisting of a spring and a damper. The lever is assumed to have a payload on the non-supported extremity. After a brief presentation of the system and also of the neural identification theory, the neural controller is obtained by replicating an existent controller using a recurrent neural network. The system is then ready to be associated with adaptive mechanisms to yield incremental improvements of the global performance. Work is presently under way to investigate the properties of some of the adaptive techniques. Computer simulations are used to evaluate the recurrent neural network controller.

Keywords— Control, Vibration, Recurrent Neural Networks, Dynamical Systems.

1 Introduction

The active control of vibrations is paramount relevance in engineering. Reduction of mechanical vibrations may contribute to the user's comfort and safety, increase the product's reliability and durability by reducing wear and can increase precision of pointing devices such as cameras and weapons. Nowadays, applications of actively control of vibrations range from home appliances and automobiles to space technology and nuclear power plants (Murphy and Bailey, 1990, Campbell and Crawley, 1994, Zhou *et al.*, 1995, Tamai and Sotelo Jr., 1995, Denoyer and Kwak, 1996, Bai and Lim, 1996, Holzrüter, 1997).

Several techniques have been used to control vibration. These techniques can be classified in two categories: passive and active. The former require the use of passive components such as vibration dampers and dynamic absorbers, which are conventional and well known (Rao, 1990). However, the passive approach suffers from the major drawback of being ineffective at low frequencies. On the other hand, active control approaches provide numerous advantages, such as, better low frequency performance, smaller size and weight, robustness to uncertainties and adaptability to unforeseen conditions. Thus, active vibration control techniques are promising alternatives to conventional passive methods (Soong, 1990). The choice of the approach to be used in active control of vibration, basically, depends of the characteristics of the system to be controlled, of performance desired and of available design tools. Sometimes, it can be necessary to combine more than one approach to achieve the desired performance or to provide some additional performance. Specifications in term of robustness, for example, can suggest using a robust approach of design likes H_∞ , μ syn-

thesis or LQR. Nevertheless, only one of the mentioned approaches may not satisfy all the specifications, and it may be necessary that the designed controller has to present an adaptive feature in real time. In this situation, the controller designed initially can be replicated by a ANN (Miller *et al.*, 1995) and later, a learning method can be embedded the neural controller in way to provide a desired global performance.

Widrow and Smith (1964) applied this method to a version of the pole-balancing problem, and Widrow refers to this as a method for constructing an expert system by acquiring knowledge from an existing expert. One might question the utility of this method on the grounds that if there already exists an effective controller, why would it be useful to have another one in the form of a ANN? To answer this question, Miller *et al.* (1995) cite at least more two reasons, besides that aforementioned, to a designer makes a copy of an existent controller by using an ANN. After a period of skepticism, evolutions of the computational tools as well as new contributions in the theory revived the interest in ANN'S theory and its several applications, among them, the identification of dynamic systems, application class in which the copy method proposed initially by Widrow and Smith (1964) can be mentioned as a private case. After this revive, many contributions in ANN's theory to identifying and controlling dynamical system were presented and it continues until the current days, with many researchers studying this method to apply as to linear as to nonlinear (Narendra and Parthasarathy (1990), Bialasiewicz and Soloway (1990), Hyland (1991), Baz (1991), Napolitano *et al.* (1993), Kuschewski *et al.* (1993), Rao and Damle (1994), Yazdizadeh and Khorasani (1996), Yazdizadeh (1997), Hirasawa *et al.* (1999), Qiang *et al.* (1999), Griño *et al.* (2000), Djamaï *et al.* (2000), Rubaai and Kotaru (2000), Yazdizadeh *et al.* (2000), Araújo *et al.* (2000), Araújo and Yoneyama (2000)).

It is known that linear controllers design to present a good trade-off between disturbance rejection and tracking cannot be a simple task. This paper proposes to replicate an existing controller by a recurrent neural network (RNN). The existing controller is a state feedback with observer, where the state estimator was designed by pole dominance using Ackermann's formula and the state feedback was designed by LQR approach. After the replication of the controller the RNN replace it in the electromechanical system. The aim is to provide adaptation capability to the original system and then make possible that one use some adaptation method to improve the system performance and the trade-off between disturbance rejection and tracking, but the adaptation mechanism to be used exceed the scope of this paper, which show the copy procedure using a RNN. In section 2 the electro-mechanical system model is briefly described. Section 3 contains a brief presentation of the replicating problem, under the general topic of identification. Section 4 presents the replication procedure, including the chosen of the structural of the neural identifier used in the replication procedure. In the section 5, the results are analyzed by digital simulations, comparing the performance of original system with each one controller, the state feedback controller with observer and the RNN controller.

2 The linear model for the electromechanical system

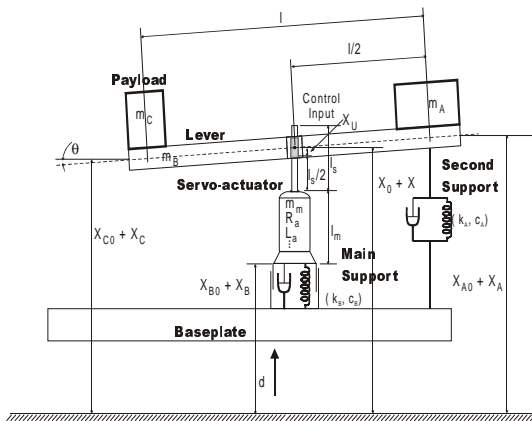

Figure 1 – The proposed electro-mechanical system.

The proposed electro-mechanical system consists of a lever supported in two points. The main support has a DC servo-actuator to provide vertical displacements that are used for vibration suppression. The second support is passive, consisting of a spring and a damper. The lever is assumed to have a payload on the non-supported extremity. The objective is to reduce the transmission of vibrations between the baseplate and the payload. This is achieved by using the DC servo-actuator in such a way as to produce displacements that oppose the effects of the undesirable disturbances (Figure 1).

The dynamical linear model for this system may be divided in two SISO sub-models. The first, represented by equation (1) is the input/output model between a reference signal and the measured system output.

$$\begin{aligned} \dot{\mathbf{x}}_R(t) &= \mathbf{A}_R \mathbf{x}_R(t) + \mathbf{B}_R \mathbf{u}_R(t) \\ Y_R(t) &= \mathbf{C}_R \mathbf{x}_R(t) \end{aligned} \quad (1)$$

where:

$$\begin{aligned} \mathbf{A}_R &= \begin{bmatrix} \mathbf{I} & \mathbf{0} & \mathbf{0} \\ \mathbf{0} & [\mathbf{M}] & \mathbf{0} \\ \mathbf{0} & \mathbf{0} & \mathbf{I} \end{bmatrix}^{-1} \begin{bmatrix} \mathbf{0} & \mathbf{I} & \mathbf{0} \\ -[\mathbf{K}] & -[\mathbf{C}] & [\mathbf{P}_1] \\ \mathbf{0} & \mathbf{0} & [\mathbf{A}_m] \end{bmatrix} \approx \\ & \approx \begin{bmatrix} 0 & 0 & 1 & 0 & 0 & 0 \\ 0 & 0 & 0 & 1 & 0 & 0 \\ -88,98 & -10,59 & -8,90 & -1,06 & 0,85 & 0,08 \\ -1,90 & -4,76 & -0,19 & -0,48 & 0 & 0 \\ 0 & 0 & 0 & 0 & 0 & 1 \\ 0 & 0 & 0 & 0 & 0 & -25,32 \end{bmatrix} \\ \mathbf{B}_R &= \begin{bmatrix} \mathbf{I} & \mathbf{0} & \mathbf{0} \\ \mathbf{0} & [\mathbf{M}] & \mathbf{0} \\ \mathbf{0} & \mathbf{0} & \mathbf{I} \end{bmatrix}^{-1} \begin{bmatrix} \mathbf{0} \\ [\mathbf{P}_2] \\ [\mathbf{P}_3] \end{bmatrix} \approx [0 \ 0 \ 0,08 \ 0 \ 0 \ 323,4]^T \\ \mathbf{C}_R &= \begin{bmatrix} 1 & -\frac{l}{2} & \mathbf{0} \end{bmatrix} = [1 \ -2,5 \ 0 \ 0 \ 0 \ 0] \end{aligned}$$

The second sub-model, represented by equation (2) is the input/output model between a disturbance, type mechanical vibration in the baseplate, and the measured system output.

$$\begin{aligned} \dot{\mathbf{x}}_D(t) &= \mathbf{A}_D \mathbf{x}_D(t) + \mathbf{B}_D \mathbf{u}_D(t) \\ Y_D &= \mathbf{C}_D \mathbf{x}_D(t) \end{aligned} \quad (2)$$

where:

$$\begin{aligned} \mathbf{A}_D &= \begin{bmatrix} \mathbf{I} & \mathbf{0} & \mathbf{0} \\ \mathbf{0} & [\mathbf{M}] & \mathbf{0} \\ \mathbf{0} & \mathbf{0} & \mathbf{1} \end{bmatrix}^{-1} \begin{bmatrix} \mathbf{0} & \mathbf{I} & \mathbf{0} \\ -[\mathbf{K}] & -[\mathbf{C}] & [\mathbf{P}_4] \\ \mathbf{0} & \mathbf{0} & \mathbf{0} \end{bmatrix} \approx \\ & \approx \begin{bmatrix} 0 & 0 & 1 & 0 & 0 \\ 0 & 0 & 0 & 1 & 0 \\ -88,98 & -10,59 & -8,90 & -1,06 & 88,98 \\ -1,90 & -4,76 & -0,19 & -0,48 & 1,90 \\ 0 & 0 & 0 & 0 & 0 \end{bmatrix} \\ \mathbf{B}_D &= \begin{bmatrix} \mathbf{I} & \mathbf{0} & \mathbf{0} \\ \mathbf{0} & [\mathbf{M}] & \mathbf{0} \\ \mathbf{0} & \mathbf{0} & \mathbf{1} \end{bmatrix}^{-1} \begin{bmatrix} \mathbf{0} \\ [\mathbf{P}_5] \\ [\mathbf{P}_6] \end{bmatrix} \approx [0 \ 0 \ 8,90 \ 0,19 \ 1]^T \\ \mathbf{C}_D &= \begin{bmatrix} 1 & -\frac{l}{2} & \mathbf{0} \end{bmatrix} = [1 \ -2,5 \ 0 \ 0 \ 0] \end{aligned}$$

The estimator gain matrix calculated by Ackermann's formula and the state feedback gain matrix calculated by LQR approach was given, respectively by:

$$\mathbf{L} \equiv \begin{bmatrix} 178,15 \\ 53,94 \\ 85,27 \\ -238,82 \\ 21765,08 \\ -4455,59 \end{bmatrix}; e \mathbf{K} \equiv \begin{bmatrix} 2,93 \times 10^3 \\ -7,90 \times 10^3 \\ 1,12 \times 10^2 \\ -3,43 \times 10^2 \\ 2,32 \\ 1,80 \times 10^{-1} \end{bmatrix} \quad (3)$$

In presence of the reference and disturbance signals, the main system output, here denoted by $y(t) = X_C(t)$, is the sum of $Y_R(t)$ and $Y_D(t)$, as one can see in the

Figure 2, where the base-observed state feedback control is showed.

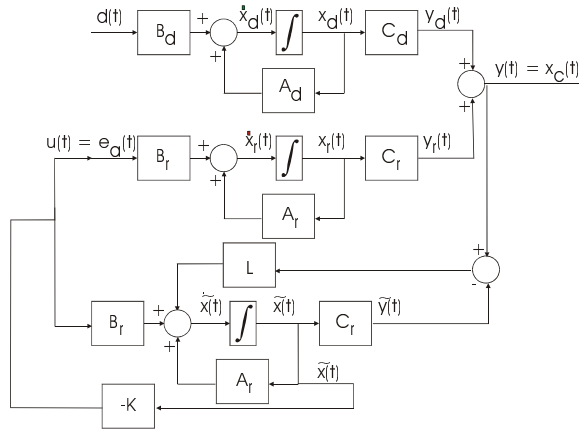

Figure 2 – Base-observed feedback control for the studied electro-mechanical system.

3 Preliminaries and basic concepts about neural network to identification and control

System characterization and identification are fundamental problems in systems theory, the problem of characterization is concerned with the mathematical representation of a system; a model of a system is expressed as an operator P from an input space \mathcal{U} into an output space \mathcal{Y} and the objective is to characterize the class \mathcal{P} to which P belongs. Given a class \mathcal{P} and the fact that $P \in \mathcal{P}$, the problem of identification is to determine a class $\hat{\mathcal{P}} \subset \mathcal{P}$ and an element $\hat{P} \in \hat{\mathcal{P}}$ so that \hat{P} approximate P in some desired sense. In dynamic systems the spaces \mathcal{U} and \mathcal{Y} are generally assumed to be bounded Lebesgue integrable functions on the interval $[0, T]$ or $[0, \infty)$. Specified input-output pairs define the operator P implicitly. Narendra and Parthasarathy (1990) said that, the choice of the class of identification models $\hat{\mathcal{P}}$, as well as the specific method used to determine \hat{P} , depends upon a variety of factors that are related to the accuracy desired, as well as analytical tractability. These include the adequacy of the model \hat{P} to represent P , its simplicity, the ease with which it can be identified, how readily it can be extended if it does not satisfy specifications and finally whether

the \hat{P} chosen is to be used off line or on line. In practical applications many of these decisions naturally depend upon the prior information that is available concerning the plant to be identified.

In dynamical systems, the operator P defining a given plant is implicitly defined by the input-output pairs of time functions $u(t)$, $y(t)$, $t \in [0, T]$. The objective of the identification is to determine \hat{P} so that:

$$\|\hat{y} - y\| = \|\hat{P}(u) - P(u)\| \leq \varepsilon, \quad u \in \mathcal{U} \quad (4)$$

for some desired $\varepsilon > 0$ and suitably defined norm on the output space.

It is well know that if a plant is linear time-invariant (LTI) and causal it can be described by the following set of first order ordinary differential equation in the space state form:

$$\begin{aligned} \dot{\mathbf{x}}(t) &= \mathbf{A}\mathbf{x}(t) + \mathbf{B}\mathbf{u}(t) \\ \mathbf{Y} &= \mathbf{C}\mathbf{x}(t) \end{aligned} \quad (5)$$

For a LTI, single-input single-output (SISO), controllable and observable plant the matrix \mathbf{A} and the vectors \mathbf{B} and \mathbf{C} in equation (5) can be chosen in such fashion that the discrete-time plant equation can be written as:

$$y(k+1) = \sum_{i=0}^{n-1} \alpha_i y(k-i) + \sum_{j=0}^{m-1} \beta_j u(k-j) \quad (6)$$

Notice that a similar representation is also possible for the multi-input multi-output (MIMO) case. This implies that the output at time $k+1$ is a linear combination of the past values of both the input and the output. Equation (6) motivates the choice of the following identification models:

$$\hat{y}(k+1) = \sum_{i=0}^{n-1} \hat{\alpha}_i \hat{y}(k-i) + \sum_{j=0}^{m-1} \hat{\beta}_j u(k-j) \quad \text{(Parallel model)} \quad (7)$$

$$\hat{y}(k+1) = \sum_{i=0}^{n-1} \hat{\alpha}_i y(k-i) + \sum_{j=0}^{m-1} \hat{\beta}_j u(k-j) \quad \text{(Series-parallel model)} \quad (8)$$

Where $\hat{\alpha}_i (i=0, 1, \dots, n-1)$ and $\hat{\alpha}_j (j=0, 1, \dots, m-1)$ are adjustable parameters. The output of the parallel identification model (equation (7)) at time $k+1$ is $\hat{y}(k+1)$ and is a linear combination of its past values as well as those of the input. In the series-parallel model $\hat{y}(k+1)$ is a linear combination of the past values of the input and output of the plant.

In the last years many advances have been made in neural identification and control for identifying and controlling as nonlinear systems as linear time-invariant (LTI) systems (Narendra and Parthasarathy (1990), Rao and Damle (1994), Yazdizadeh and Khorasani (1996), Hirasawa et. al. (1999), Rubaai and Kotaru (2000), Araújo and Yoneyama (2000)). Two classes of neural networks which have received considerable attention in the area of artificial neural networks in recent years are: multilayer neural networks and recurrent neural networks. From a systems theoretic point of view, multilayer networks represent static nonlinear maps while recurrent net-

works represent dynamic feedback systems (Narendra and Parthasarathy (1990)).

In both static identification and dynamic system identification, if ANNs are used, the objective is to determine a parameter vector ($\theta^* = [W^T \ B^T]^T$), formed by the weights and the bias, which optimize a performance function J based on the output error. Back propagation is the most commonly used method for this purpose in static contexts. In a causal dynamic system an extension of this method is necessary, it was named dynamic back propagation. Narendra and Parthasarathy (1990) based the works of the early 1960's, when the adaptive identification and control of dynamical systems were extensively studied, and sensitivity models were developed to generate the partial derivatives of the performance criteria with respect to the adjustable parameters of the system, said that, since conceptually the above problem is identical to that of determining the parameters of ANN's in identification and control problems, it is clear that back propagation can be extended to dynamical systems as well.

4 Replication of a dynamical controller

The controller to be copied have finite dimension and it is a LTI dynamical system. It is given by:

$$\begin{aligned} \dot{\hat{\mathbf{x}}}(t) &= (\mathbf{A}_R - \mathbf{B}_R \mathbf{K} - \mathbf{L} \mathbf{C}_R) \hat{\mathbf{x}}_R(t) + \mathbf{L} y(t) \\ \mathbf{u}(t) &= -\mathbf{K} \hat{\mathbf{x}}(t) \end{aligned} \quad (9)$$

As one can see in the section 0, to LTI systems the choice of the neural identifier structures can be based on well-established results in linear systems theory. Then, using this available knowledge about the system, we could choose the structure of the ANN to be used in the copy procedure. We used a recurrent neural network (RNN) with a linear activation function.

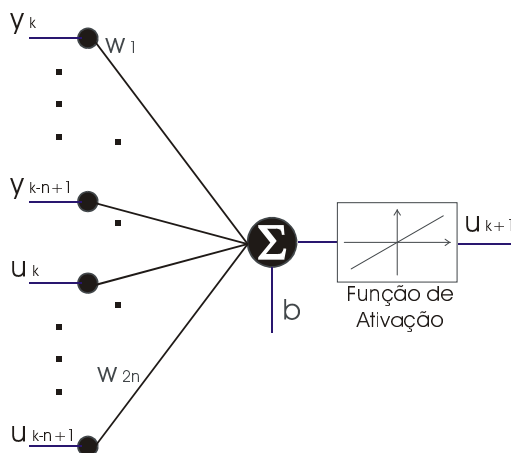

Figure 3 – Topology of the RNN.

It is clear that when a network use only linear activation functions, hidden layers are not necessary and as consequence of that, the designer don't need

to spend time to determine some characteristics of the network as of number of hidden layers, number of neurons in each layers and activation function of each neuron. From the system dimension (n), we could determine the number of neurons in the input layer and in the output layer. The number of auto-regresses added to the number of exogenous-regresses give the number of neurons in the input layer and the number of output in the system to be copied give the number of neurons in the output layer. Thereby the topology of the RNN to be used in the copy procedure is completely determined (Figure 3).

The network, with appropriately adjusted weights and bias, can substitute the BOSF controller in the master system (Figure 4) without significant decline in the global performance.

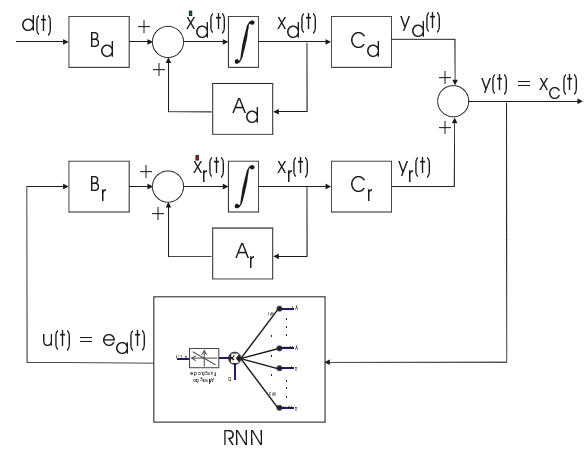

Figure 4 –The studied electro-mechanical system with the RNN controller.

5 Conclusions

An introduction to the problem of neural identification of dynamical systems was doing and a recurrent neural network structure was successful proposed, based in the explained theory, to copying a base-observed state feedback controller currently running actively in the control of mechanical vibrations. The copy procedure was doing successfully, and the RNN controller substituted satisfactorily the controller in the original system (Figure 5). Therefore, we consider the proposed aims achieved.

The output error between the system response using the BOSF controller and RNN controller show that the system using the RNN controller is most sensible than the system using the BOSF controller when the disturbance is changed abruptly (Figure 6). This fact suggests a more detailed study about the adjustment of the parameters of the network. Therefore, with a RNN controller working properly, we can study the application of adapting tools, for example; reinforcement learn, to changing on line some of the current characteristics of the master system, as adaptation to change in the mass of the payload and

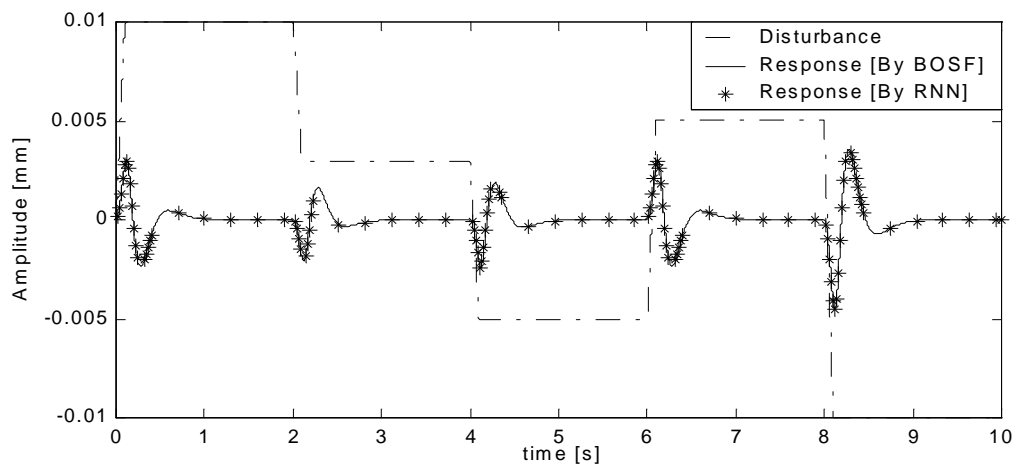

Figure 5 – Comparing the system response to a dynamic disturbance with BOSF controller and with RNN controller.

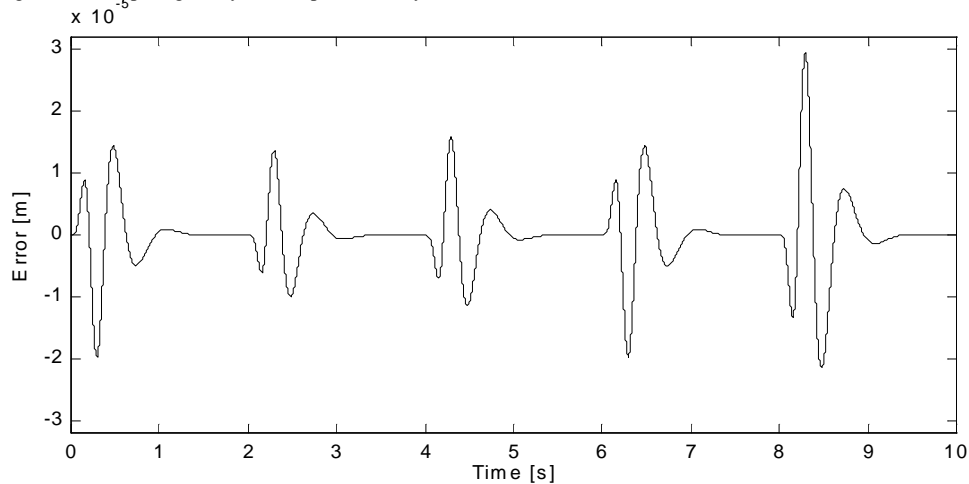

Figure 6 – Error between the system response to a dynamic disturbance with BOSF controller and with RNN controller.

to improve the desired trade-off between the disturbance rejection and tracking, which is not possible by using the BOSF controller.

Acknowledge

The authors are grateful to FAPESP (Fundação de Amparo à Pesquisa do Estado de São Paulo) for the financial support rendered through the process 99/02409-4.

References

Araujo, F.M.U., Araújo, C. S., Dana, S. S. and Yoneyama, T., 2000, “Um Controlador Neural Tipo PI-I2 Estendido Para Isolamento de Vibrações”, Proc. in cdrom of the Congresso Nacional de Engenharia Mecânica – CONEM/2000, Natal, August.

Araujo, F.M.U. and Yoneyama, T., 2000, “Análise da Sensibilidade Paramétrica no Controle de um Sistema Eletromecânico: Casos Clássico e Neural”, Proc. in cdrom of the XIII Congresso Brasileiro de Automática – CBA/2000, Florianópolis, September.

Bai, M. R. and Lin, G. M., 1996, “The Development Of A DSP-Based Active Small Amplitude Vibration Control System For Flexible Beams

By Using The LQG Algorithms And Intelligent Materials”, Journal of Sound and Vibration, Vol. 189, No. 4, pp. 411-427, December.

Bialasiewicz, J. T. and Soloway, D., 1990, “Neural Network Modeling of Dynamical Systems”, Proc. of International Symposium on Intelligent Control, pp.500-505.

Braz, A., 1991, “A Neural Observer for Dynamic Systems”, Journal of Sound and Vibration, vol. 1, pp.151-160, August.

Campbell, M. E. and Crawley E. F., 1994, “The SISO Compensator For Lightly Damped Structures”, Proc. of the American Control Conference, pp.3464-3469, Baltimore, Maryland.

Denoyer, K. K. and Kwak, M. K., 1996, “Dynamic Modeling And Vibration Suppression Of A Slewing Structure Utilizing Piezoelectric Sensors and Actuator”, Journal of Sound and Vibration, Vol. 189, No. 1, pp. 13-31, January.

Djamai, L., Coirault P. and Mehdi, D., 2000, “Identification of Subsonic Jet by Dynamical Recursive Neural Network and Validation by Lyapunov Exponents”, Proc. of the American Control Conference, pp. 1710-1714, Chicago, Illinois, June.

- Griño, R., Cembrano, G. and Torras, C., 2000, "Nonlinear System Identification Using Additive Dynamic Neural Networks – Two On-Line Approaches", IEEE Trans. On Circuits and Systems – Part I: Fundamental Theory and Applications, vol. 47, n° 2, February.
- Hirasawa, K., Jinglu Hu, Murata, J., Chunzhi Jin, Yotsumoto, K., Katagiri, H., 1999, "Identification of Nonlinear Dynamic Systems by Using Probabilistic Universal Learning Networks", Proc. of the International Joint Conference on Neural Networks – IJCNN'99, vol. 3, pp. 2123-2128, July.
- Holzhüter, T., 1997, "LQG approach for the high-precision track control of ships", IEE proc. Control Theory Appl., vol. 144, n° 2, March.
- Kuschewski, J. G., Hui, S. and Zak, S. H., 1993, "Application of Feedforward Neural Networks to Dynamical System Identification and Control", IEEE Trans. On Control Systems Tech., vol. 1, n° 1, pp.37-49, March.
- Miller, W. T., Sutton, R. S. e Werbos, P. J., 1995, "Neural Networks for Control", MIT Press, Massachusetts.
- Murphy G. V. and Bailey, J. M., 1990, "LQG/LTR Robust Control System Design For A Low-Pressure Feedwater Heater Train", IEEE, Proc. of 1990 Southestcon, pp. 853-856.
- Napolitano, M. R., Ching, I. C. and Nutter, R., 1993, "Application of Neural Observer as State Estimator in Active Vibration Control of a Cantilever Beam", Smart Materials and Structures Journal, vol. 1, n° 1, pp.69-75.
- Narendra, K. S. and Parthasarathy, K., 1990, "Identification and Control of Dynamical Systems Using Neural Networks", IEE Trans. On Neural Networks, vol. 1, n° 1, pp. 4-27, March.
- Qiang, L., Huiyi, W., Konghui, G., 1999, "Identification and Control of Four-Wheel-Steering Vehicles Based on Neural Network", Proc. of the IEEE International Vehicle Electronics Conference – IVEC'99, vol. 1, pp. 250-253, September.
- Rao, S. S., 1990, "Mechanical Vibration", Reading, MA, Addison-Wesley.
- Rao, V. and Damle, R., 1994, "Identification and Control of Smart Structures Using Neural Networks: A Survey", Proc. of the 33rd Conference on Decision and Control, Lake Buena Vista, FL, December.
- Rubaai, A. and Kotaru, R., 2000, "Online Identification and Control of a DC Motor Using Learning Adaptation of Neural Networks", IEE Trans. On Industry Applications, vol. 36, n° 3, May/June.
- Soong, T. T., 1990, "Active Strutral Control: Theory and Praticce", New York, Longman Scientific & Technical.
- Tamai, E. H. and Solet Jr., J., 1995, "LQG-Control Of Active Suspension Considering Vehicle Body Flexibility" Proc. of the 4th IEEE Conference on Control Applications, pp. 143-147.
- Widrow, B. e Smith, F. W., 1964, "Pattern-recognizing control systems", Computer and Infomation Sciences (COINS) Proceedings, Washington, D.C.: Spartan ,Washington.
- Yazdizadeh, A., 1997, "Identification of Nonlinear Systems Using Dynamic Neural Network", Ph.D. dissertation.
- Yazdizadeh, A. and Khorasani, K., 1996, "Nonlinear System Identification Using Adaptive Time Delay Neural Network", Proc. of the World Congr. Neural Networks, pp.482-485.
- Yazdizadeh, A., Khorasani, K. and Patel, R. V., 2000, "Identification of a Two-Link Flexible Manipulator Using Adaptive Time Delay Neural Networks", IEEE trans. On Systems, Man, And Cybernetics – Part B: Cybernetics, vol. 30, n° 1, February.
- Zhou, C., Whiteley, J. R., Misawa, E. A. and Gasem, K. A. M., 1995, "Applications of Enhanced LQG/LTR For Distillation Control", IEEE trans. Control Systems, August, pp.56,-63.